

# UC-FCB-T

## Crestron Flex R-Series Mobile UC System for Microsoft Teams® Rooms



- *Rapid deployment mobile UC system for presenting, calling, conferencing, and collaborating*
- *Supports Microsoft Teams® conferencing software*
- *Includes a soundbar with a built-in conferencing camera featuring a 150° field of view (UC-SB1-CAM-FLEX)*
- *15 ft microphone range with adaptive beamforming technology*
- *Supports most 50 in. to 60 in. displays (not included)*
- *Easy to provision and manage with the XiO Cloud® service*
- *Premium-level support with Crestron Flex Care (optional)*
- *Enterprise-grade security for connecting and communicating over any enterprise or SMB network*

The Crestron Flex R-Series mobile UC system can be rapidly deployed to provide convenient video conferencing in a variety of professional settings, such as corporate, education, healthcare, or manufacturing environments. A Crestron unified communications engine assembly comes pre-installed for easy component installation and hookup. All components mount to a wheeled cart to bring collaboration to wherever it is needed.

### Native Microsoft Teams® Software Experience

R-Series UC systems feature Microsoft Teams conferencing software for easy collaboration and content sharing.

### 10.1 in. Touch Screen

With a large 10.1 in. (257 mm) capacitive touch screen display, the Crestron® tabletop touch screen ([TS-1070-B-S](#)) provides superior conferencing control for R-Series systems.

### Crestron® Smart Soundbar and Camera

The UC-SB1-CAM-FLEX soundbar bundles a high-definition camera and adaptive beamforming microphone with high-powered stereo speakers and advanced digital signal processing to deliver full-duplex, echo-free speakerphone performance.

The soundbar's integrated camera features an ultra wide-angle 150° diagonal field of view to capture any space in Full HD 1080p video resolution. Genius Framing digital autozoom detects the people in the room and frames them perfectly to eliminate the hassle of manual control or stored presets.

For more information, refer to the [UC-SB1-CAM-FLEX](#) product page.

### UC Engine Assembly

Microsoft Teams video conferencing solutions are powered by the UC Engine (UC-ENGINE-S-T), a powerful ASUS® Mini PC running Microsoft Teams software. The UC Engine Assembly (UC-BRKT-200-S-T-ASSY) streamlines the installation of a Crestron® UC system by providing the UC Engine on one ready-to-mount bracket that attaches to the inside frame of an R-Series mobile UC system.

### XiO Cloud® Provisioning and Management Service

Crestron Flex R-Series systems are enterprise grade solutions that are equipped for mass deployment. R-Series systems are easily manageable with the XiO Cloud service, an IoT (Internet of Things) based platform for remotely provisioning, monitoring, and managing Crestron devices. The service allows for the deployment and management of thousands of devices in the amount of time it previously took to manage just one. Advanced security features ensure privacy, reliability, and compliance with your organization's IT policies.

For more information, visit [www.crestron.com/xiocloud](http://www.crestron.com/xiocloud).

### Premium-Level Support

Crestron Flex Care is an optional subscription service that automatically renews annually, providing 24/7 live remote technical support, an extended five year warranty on Crestron® hardware, expedited advance replacements, and a discounted rate for on-site support.

Visit [www.crestron.com/flexcare](http://www.crestron.com/flexcare) for additional information.

### Deployment Resources

View the [Crestron Flex Pre-Deployment Checklist](#) to help plan your Crestron Flex installation.

# UC-FCB-T

## Crestron Flex R-Series Mobile UC System for Microsoft Teams® Rooms

### Specifications

#### Included Components

<b>Wheeled Cart</b>	Metal frame comprised of: (4) Caster wheels; VESA® compliant display mounting bracket; Custom shelving for Crestron components; Power and Ethernet cable retractors
<b>TS-1070-B-S</b>	10.1 in. touch screen, black
<b>UC-SB1-CAM-FLEX</b>	UC video conference smart soundbar
<b>UC-BRKT-200-S-T-ASSY</b>	UC Bracket Assembly for Microsoft Teams Rooms systems, comprised of: <ul style="list-style-type: none"><li>• UC-ENGINE-S-T: UC Engine for Microsoft Teams video</li><li>• HD-CONV-USB-200: HDMI® to USB 3.0 converter for content ingest</li><li>• Mounting hardware</li><li>• EDID Passthrough: HDMI Female-to-Male</li></ul>
<b>CBL-CAT5E-7</b>	Ethernet LAN cable for UC Engine, RJ45-to-RJ45, black, 7 ft (2.1 m)
<b>CBL-HD-20</b>	HDMI cable for content source, Type A male-to-male, 20 ft (6.1 m)
<b>CBL-USBC-HD-9</b>	USB-C® to HDMI converter cable, USB Type-C® male to HDMI Type A male, 9 ft (2.74 m)
<b>CEN-SW-POE-5</b>	5-Port POE switch
<b>PWE-4803RU</b>	PoE injector for touch screen

#### Smart Soundbar and Camera

<b>Speakers</b>	Stereo 2-way, 20 W per channel, 3 in. (76 mm) woofers (2), 1 in. (25 mm) dome tweeters (2), and 3 in. x 4-3/8 in. (76 x 112 mm) passive radiators (2), 80 Hz to 20 kHz (±3 dB) frequency response, 91 dB SPL @ 1 m output level (both channels driven at full power)
<b>Microphone</b>	Linear quad-element far-field adaptive beamforming microphone array, 15 ft (4.6 m) <sup>1</sup> pickup range, 180° horizontal pickup angle, 20 Hz to 8 kHz frequency response

<b>Audio DSP</b>	Acoustic echo cancellation, dereverberation, automatic gain control, dynamic noise suppression, adaptive beamforming, speaker volume control; Full-duplex IEEE 1329 Type 1 compliant
<b>Camera Optics</b>	12 Megapixel 1/2.3 in. CMOS sensor, ultra wide angle, f/2.8 aperture
<b>Camera Field of View</b>	150° diagonal, 120° horizontal, 90° vertical
<b>Camera Processing</b>	Intel Movidius® Myriad® X VPU with Neural Compute Engine hardware accelerator, dynamic light optimization, auto white balance, autozoom
<b>Camera Autozoom</b>	Genius Framing automatic lossless digital zoom intelligently frames people in the room
<b>Camera Noise Reduction</b>	3D noise reduction, bias compensating spatio-temporal filtering, wide area chroma filtering, flicker elimination
<b>Camera Scaling</b>	Real-time scaling, dewarping, and perspective correction
<b>Camera Resolution</b>	HD 1080p @ 30 fps
<b>Camera Color Space</b>	YCbCr 4:2:0, YCbCr 4:2:2, MJPEG
<b>USB</b>	USB 3.0 Type-B port; UAC 1.0, UVC 1.1, & HID; 2-channel stereo far-end/content signal input, 2-channel mono microphone signal output, camera output; for audio, video, and communications interface to UC Engine
<b>Analog Audio Input</b>	2-Channel stereo via 3.5 mm TRS mini-phone jack, fixed level (bypasses DSP), 1 Vrms maximum per channel for full rated output, for in-room amplification of an external audio source
<b>Analog Audio Output</b>	2-Channel stereo via 3.5 mm TRS mini-phone jack, fixed level, 1 Vrms maximum, feeds amplified audio content to an assistive listening system
<b>Status Bar</b>	(1) Multi-segment RGBY LED zero-center mutually diverging linear bargraph; Indicates the speaker volume, microphone mute, and speaker mute in red and green LEDs

# UC-FCB-T

## Crestron Flex R-Series Mobile UC System for Microsoft Teams® Rooms

<b>Main Power</b>	IEC 60320 C14 main power inlet (power cord included), 500 mA maximum @ 100-240 VAC, 50/60 Hz
<b>Enclosure</b>	Lightly textured gunmetal black finish, plastic housing, perforated stainless steel grilles, die-cast aluminum rear cover, steel hinged mounting bracket
<b>Mounting</b>	Freestanding or surface wall mount at ear/face level
<b>Dimensions</b>	Height: 4.57 in. (117 mm) Width: 43.60 in. (1108 mm) Depth: 3.90 in. (100 mm)

Refer to the [UC-SB1-CAM-FLEX](#) product page for additional information.

### Tabletop Touch Screen

<b>Touch Screen</b>	10.1 in. (257 mm) diagonal capacitive multi-touch TFT active matrix color LCD, 1920 x 1200 pixels, displays Microsoft Teams UI
<b>Ethernet</b>	100 Mbps, auto switching, auto negotiating, auto discovery, full/half duplex, TCP/IP, UDP/IP, CIP, DHCP, SSL, TLS, SSH, SFTP (SSH File Transfer Protocol), IEEE 802.1X, SNMP, IPv4 or IPv6, Active Directory® service authentication, HTTPS web browser setup, XiO Cloud® client, IEEE 802.3at compliant
<b>Power over Ethernet</b>	IEEE 802.3at Type 2 compliant PoE+ PD (Powered Device); Normally requests 15 W from an 802.3at Type 2 PSE with LLDP advanced power management; With room scheduling and USB enabled, requests 18 W from an 802.3at Type 2 PSE with LLDP; Requests 30 W (PoE+ Class 4) from an 802.3at Type 2 PSE without LLDP; Requests 15.4 W (PoE Class 0) from an 802.3af (or 802.3at Type 1) PSE
<b>PoE Injector</b>	A PoE injector is included to power the touch screen if network PoE is not available
<b>Construction</b>	Plastic, smooth black finish, edge-to-edge glass with black surround
<b>Dimensions</b>	Height: 5.29 in. (134 mm) Width: 9.63 in. (245 mm) Depth: 4.67 in. (119 mm)

<b>Weight</b>	2.44 lb (1105 g)
---------------	------------------

Refer to the [TS-1070-B-S](#) and [PWE-4803RU](#) product pages for additional information.

### UC Engine Assembly

<b>Mini PC</b>	ASUS Mini PC, Intel Core® processor with Windows® 10 IoT Edition OS and 100/1000 Mbps Ethernet connectivity
<b>UC Client</b>	Microsoft Teams Rooms with Skype® for Business software functionality
<b>Management Client</b>	XiO Cloud Service
<b>Content Ingest</b>	HDMI input via HDMI to USB 3.0 converter (model HD-CONV-USB-200)
<b>Display Output</b>	Single or dual display support
<b>Display Output Resolution</b>	1080p
<b>Power</b>	65 W via external 100-240VAC, 50/60 Hz adapter (included)
<b>Construction</b>	Metal mounting bracket, black, preassembled with UC Engine and USB to HDMI converter
<b>Mounting</b>	Surface wall mount behind the display device, or attach to the rear of the display device via the bolts attaching the display to a VESA® compliant display mount; the bracket includes mounting holes on both side edges, spaced 100, 200, and 300 mm vertically, to allow for attachment to either side of the display mounting plate
<b>Dimensions</b>	Height: 15.00 in. (381 mm) Width: 14.50 in. (368 mm) Depth: 1.72 in. (44 mm)

# UC-FCB-T

## Crestron Flex R-Series Mobile UC System for Microsoft Teams® Rooms

### Wheeled Cart

<b>Wheels</b>	(4) Casters
<b>Cable Management</b>	Ethernet cable retractor; Power cable retractor; Cable management kit consisting of (2) large and (2) small openings
<b>Display Mounting</b>	VESA® compliant mounting bracket for 50 in. to 60 in. displays
<b>Device Mounting</b>	Custom shelf beneath the display mounting bracket for the included touch screen (TSW-1060); Custom mounting bracket affixed above the display mounting bracket for the included soundbar and camera (SB1-CAM-FLEX)
<b>Construction</b>	Steel subframe
<b>Dimensions</b>	Height: 68.9 in. (1750 mm) without display and display bracket Width: 43.5 in. (1105 mm) without display and display bracket Usable Depth: 4.3 in. (109 mm)
<b>Cart Weight</b>	206 lbs
<b>Compliance</b>	UL® listed for US and Canada

### Models

#### UC-FCB-T

Crestron Flex R-Series Mobile UC System for Microsoft Teams® Rooms

#### UC-FCB-Z

Crestron Flex R-Series Mobile UC System for Zoom Rooms™ Software

#### UC-FCM-T

Crestron Flex R-Series Plus Mobile UC System for Microsoft Teams® Rooms

#### UC-FCM-Z

Crestron Flex R-Series Plus Mobile UC System for Zoom Rooms™ Software

#### UC-FCMX-T

Crestron Flex R-Series Plus Mobile UC System with BYOD Support for Microsoft Teams® Rooms

#### UC-FCMX-Z

Crestron Flex R-Series Plus Mobile UC System with BYOD Support for Zoom Rooms™ Software

#### UC-FCM-U

Crestron Flex R-Series Plus Mobile UC System with Universal Platform Support

### Available Accessories

For a list of available accessories, visit the [UC-FCB-T](#) product page.

### Note:

1. Microphone pickup range may vary in rooms with highly reflective infrastructure (e.g., glass walls, metal furniture, open ceilings, etc.) or above average ambient noise.

This product may be purchased from select authorized Crestron dealers and distributors. To find a dealer or distributor, please contact the Crestron sales representative for your area. A list of sales representatives is available online at [www.crestron.com/How-To-Buy/Find-a-Representative](http://www.crestron.com/How-To-Buy/Find-a-Representative) or by calling 855-263-8754.

This product is covered under the Crestron standard limited warranty. Refer to [www.crestron.com/warranty](http://www.crestron.com/warranty) for full details.

The specific patents that cover Crestron products are listed online at [patents.crestron.com](http://patents.crestron.com).

Certain Crestron products contain open source software. For specific information, please visit [www.crestron.com/opensource](http://www.crestron.com/opensource).

Crestron, the Crestron logo, and XiO Cloud are either trademarks or registered trademarks of Crestron Electronics, Inc. in the United States and/or other countries. ASUS is either a trademark or registered trademark of ASUSTeK Computer Inc. in the United States and/or other countries. HDMI is either a trademark or registered trademark of HDMI Licensing LLC in the United States and/or other countries. Intel and Intel Core are either trademarks or registered trademarks of Intel Corporation in the United States and/or other countries. Active Directory, Microsoft Teams, and Skype are either trademarks or registered trademarks of Microsoft Corporation in the United States and/or other countries. Movidius and Myriad are either trademarks or registered trademarks of Movidius Ltd in the United States and/or other countries. USB-C and USB Type-C are either trademarks or registered trademarks of USB Implementers Forum, Inc. in the United States and/or other countries. UL is either a trademark or registered trademark of Underwriters Laboratories, Inc. in the United States and/or other countries. VESA is either a trademark or registered trademark of Video Electronics Standards Association in the United States and/or other countries. Zoom Rooms is either a trademark or registered trademark of Zoom Video Communications, Inc. in the United States and/or other countries. Other trademarks, registered trademarks, and trade names may be used in this document to refer to either the entities claiming the marks and names or their products. Crestron disclaims any proprietary interest in the marks and names of others. Crestron is not responsible for errors in typography or photography.

Specifications are subject to change without notice.

©2021 Crestron Electronics, Inc.

Rev 09/13/21

# UC-FCB-T

## Crestron Flex R-Series Mobile UC System for Microsoft Teams® Rooms

Camera, Soundbar, Microphone  
(UC-SB1-CAM-FLEX)

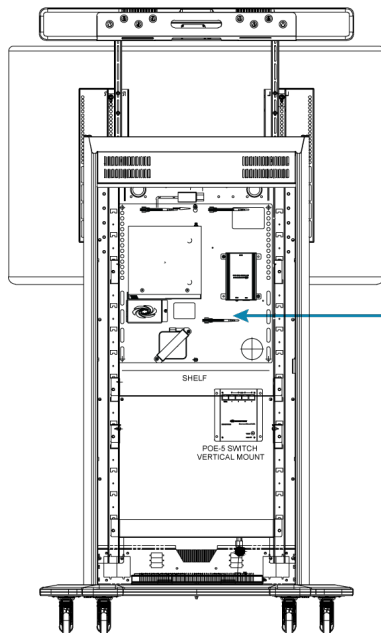
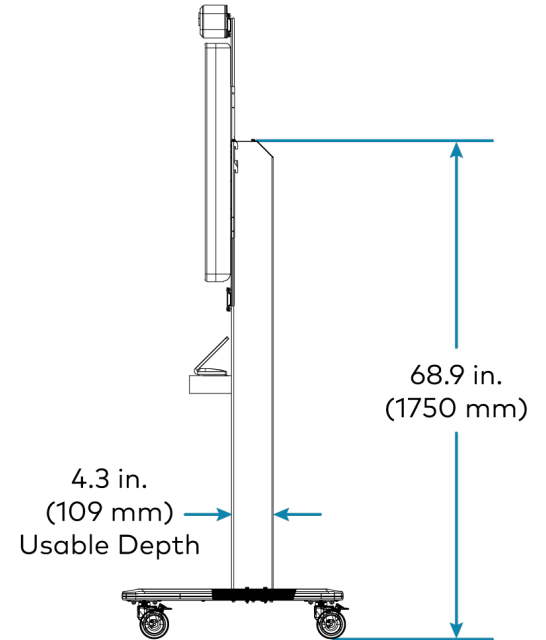
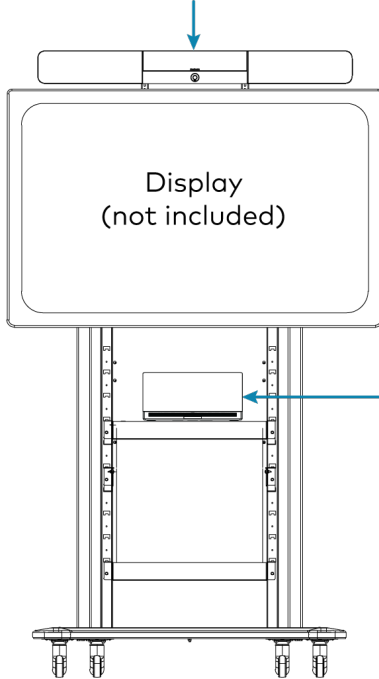

Rear cover removed for clarity

